

CLASSIC STEEL

18-0 X 15-0 X 36-6 CAPE MAY RIGHT



PART#: ISK-NO-1836-00-STD

SURFACE AREA: (ft<sup>2</sup>): 529

PERIMETER: 92'-6"

DATE: 01/01/07

LINER AREA (ft<sup>2</sup>): 657

VOLUME (US Gal): 17,365

SCALE: 1/8" = 1'-0"

SFTY COVER AREA (ft<sup>2</sup>): 830

VOLUME (Litres): 65,733



MEETS DEPTH AND SHAPE MINIMUM STANDARD ANS/SP15-2003

DIVING/SLIDING EQUIPMENT SHALL BE DESIGNED FOR SWIMMING POOLS AND SHALL BE INSTALLED IN ACCORDANCE WITH THE DIVING/SLIDING EQUIPMENT MANUFACTURER'S SPECIFICATIONS. PLEASE CONTACT THE DIVING/SLIDING EQUIPMENT MANUFACTURER FOR THEIR SPECIFICATIONS.

6' STEP

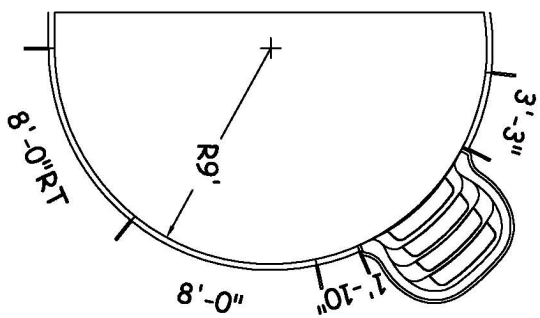

8' STEP

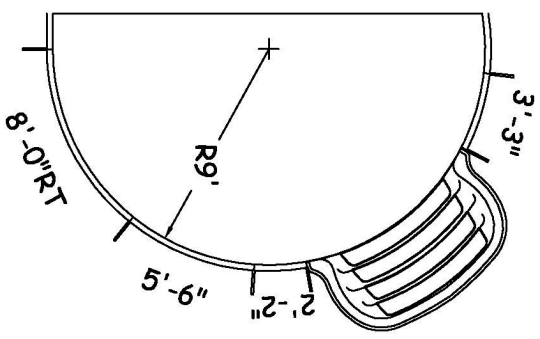

DWG#: CLN000S1836R07

SHEET: 1 OF 2

CAPE MAY

