

CLASSIC STEEL



21-3 X 16-1 X 34-5 SPECIAL FULL-L RIGHT

PART#: ISK-SV-2134-24-STD

SURFACE AREA: (ft<sup>2</sup>): 597

PERIMETER: 98'-8"

DATE: 01/01/07

LINER AREA (ft<sup>2</sup>): 648

VOLUME (US Gal): 19,598

SCALE: 1/8" = 1'-0"

SFTY COVER AREA (ft<sup>2</sup>): 764

VOLUME (Litres): 74,186



DIVING/SLIDING EQUIPMENT SHALL BE DESIGNED FOR SWIMMING POOLS AND SHALL BE INSTALLED IN ACCORDANCE WITH THE DIVING/SLIDING EQUIPMENT MANUFACTURER'S SPECIFICATIONS. PLEASE CONTACT THE DIVING/SLIDING EQUIPMENT MANUFACTURER FOR THEIR SPECIFICATIONS.

MEETS DEPTH AND SHAPE MINIMUM STANDARD ANS/SP5-2003

6' STEP

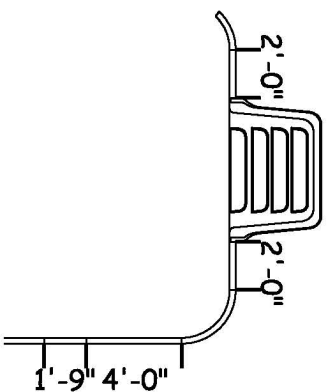

8' STEP

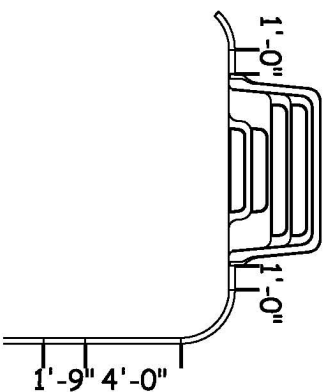

**SPECIAL FULL-L**

DWG#: CLSV24S2134R07

SHEET: 1 OF 2

