

CLASSIC STEEL
16-0 X 13-0 X 32-1 CAPE MAY RIGHT

PART#: ISK-NO-1632-00-STD	SURFACE AREA (ft ²): 408	PERIMETER: 81'-6"
DATE: 01/01/07	LINER AREA (ft ²): 497	VOLUME (US Gal): 11,362
SCALE: 1/8" = 1'-0"	SFTY COVER AREA (ft ²): 648	VOLUME (Litres): 43,010



NON-DIVING POOL
USE OF DIVING EQUIPMENT
IS PROHIBITED

MEETS DEPTH AND SHAPE MINIMUM STANDARD ANS/SP15-2003

CAPE MAY

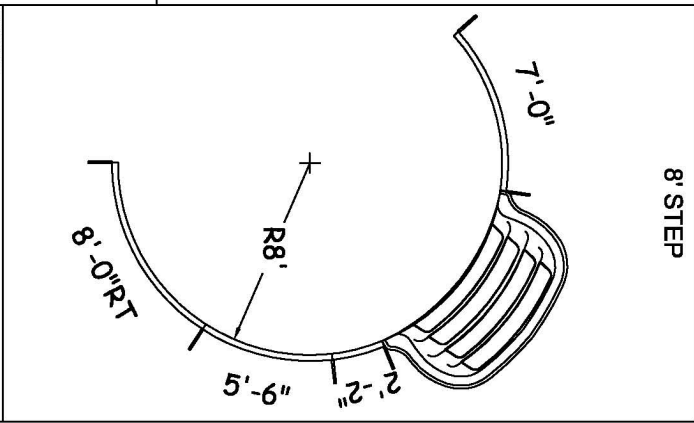
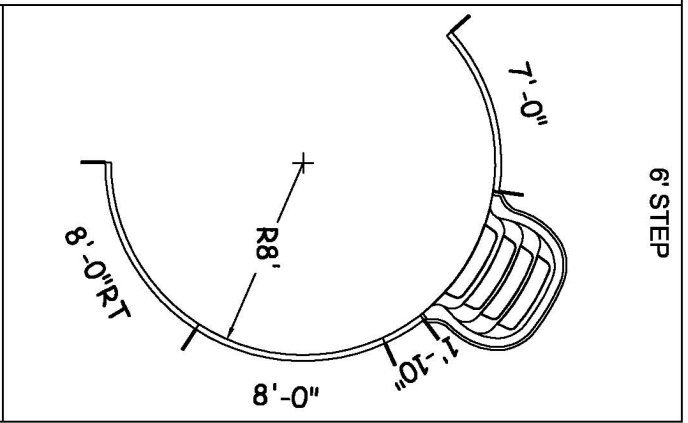

DWG#: CLN000S1632R07

